

NL DS-9

MODEL
DS-9A
DS-9C
DS-9P
DS-9AW
DS-9CW

SEWING HEAD 袋口縫ミシン

INSTRUCTION MANUAL/PARTS LIST
使用説明書/部品表

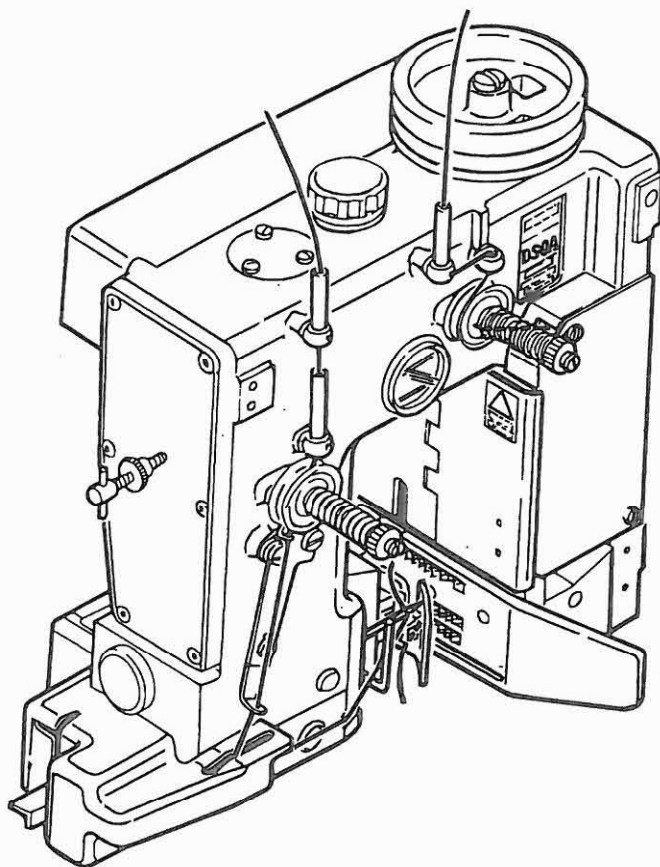

ニューロング株式会社
NEWLONG MACHINE WORKS, LTD.

No.11

ORDERING PARTS

1. Description of each part and its stamp number is described in this parts list. Screws and nuts for parts are shown adjacent to the relevant parts. When ordering parts, describe clearly stamp number with its name of part.
 2. The parts which have no Ref. Number can not be delivered independently; always order it as an assembly.
 3. A set of assembled parts is represented by the stamp number of its main parts.
 4. The last figure on the parts stamp number advances on each improvement of the parts.
 5. Parts No. described in [] of Remarks means old parts No.
- * The parts list is subject to change without prior notice.

ご注文上の注意事項

1. ご注文の際は、部品番号、部品名称、個数を明記下さい。
 2. 但し(凶番Ref.No.)の記入がない部品は、単体販売できませんので、それに該当する完備部品(組部品)をご注文ください。
 3. 組部品はその中の主パーツの刻印番号で表示してあります。
 4. 刻印番号は、その部品が改良される都度に、最後の数字が1番ずつ繰り上がり、新しい刻印番号にかわりますのでご了承下さい。
 5. 摘要欄中の [] 内は旧パーツ番号です。
- * 本部品表は改良のため予告なく変更することがあります。

CONTENTS 目次

01. MISCELLANEOUS COVERS PARTS.....	16
カバ-関係	
02-1. THREAD TENSION & OILING PARTS	18
糸調子、給油関係	
02-2. THREAD TENSION & NEEDLE THREAD OILER (DS-9AW,DS-9CW)	20
糸調子、上糸給油器関係	
03. BUSHING PARTS	22
軸受関係	
04. NEEDLE BAR & CRANK SHAFT PARTS.....	24
針棒、クランクシャフト関係	
05. PRESSER FOOT PARTS	26
押エ金関係	
06. LOOPER ROCKER & CONNECTING ROD PARTS.....	28
ルーパー揺動関係	
07-1. FEED DRIVING & THROAT PLATE PARTS (DS-9A, DS-9AW).....	30
送り機構、針板関係	
07-2. FEED DRIVING & THROAT PLATE PARTS (DS-9C, DS-9P,DS-9CW).....	32
送り機構、針板関係	
08-1. CUTTER PARTS (DS-9A, DS-9AW).....	34
カッター関係	
08-2. CUTTER PARTS (DS-9C, DS-9CW)	36
カッター関係	
09. THREAD BREAK DETECTOR PARTS.....	38
糸切れ検出関係	
DIAGRAM OF SCREW,NUT & WASHER	40, 41
ネジ、ナット、ワッシャー原寸図	
NUMERICAL INDEX OF PARTS.....	42~44
パーツ索引	

01. MISCELLANEOUS COVERS PARTS

カバー関係

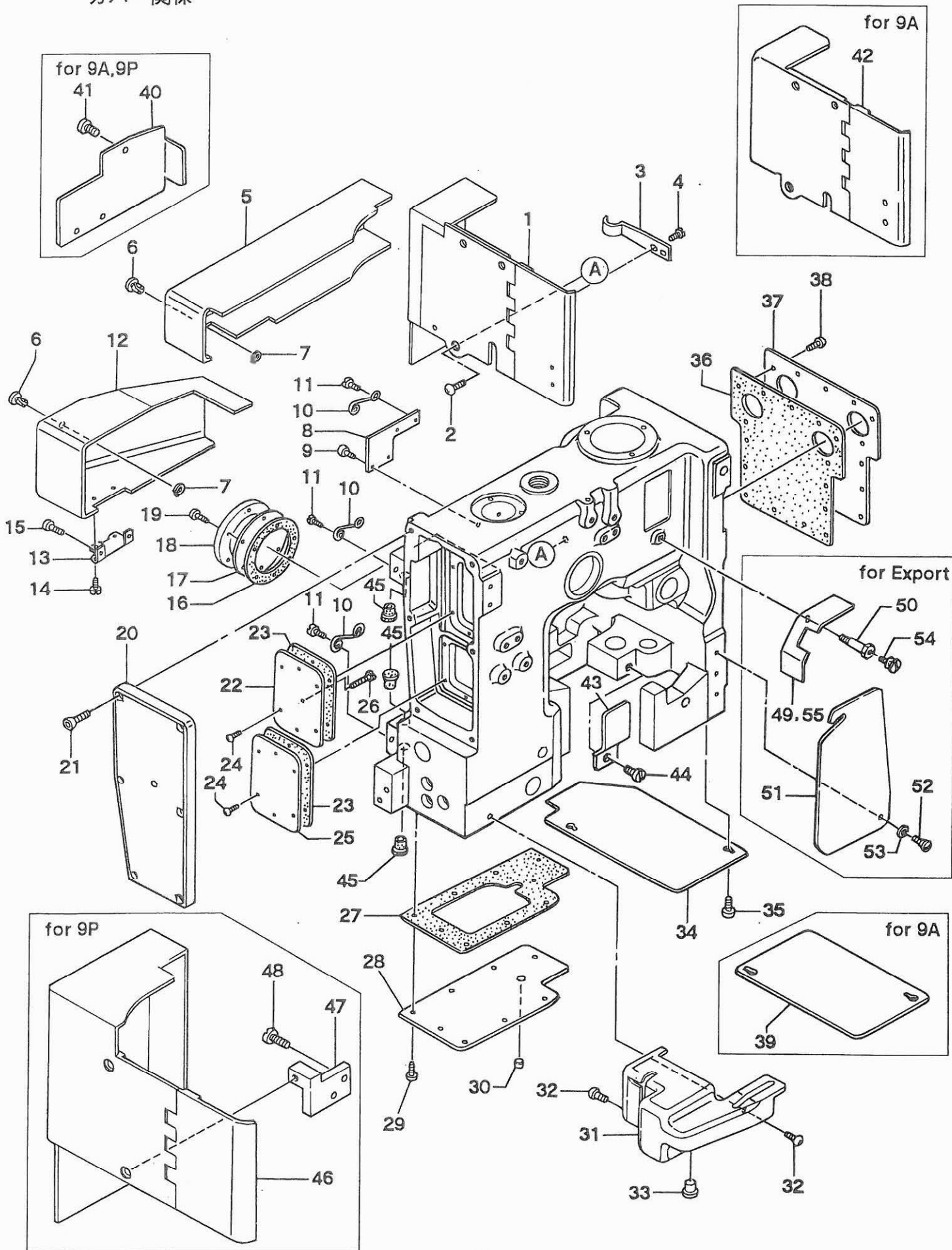

01. MISCELLANEOUS COVERS PARTS

カバー関係

図番 Ref. No.	部品番号 Part No.	部品名称 Description	個数 Q'ty					摘要 Remarks	
			A	C	P	AW	CW		
1	105017B	Cloth Plate		1	-	-	-	1	
2	7/32S32007	Screw for 105017B		2	2	2	2	2	
3	065044	Cloth Plate Spring		1	1	1	1	1	
4	11/64S40005	Screw for 065044		2	2	2	2	2	
5	305031	Cylinder Cover		1	1	1	1	1	
6	E07002	Fastener Head(T8-149)		2	3	2	2	3	
7	1RS-8	Stop Ring(S-8)		2	3	2	2	3	
8	305122	Fastener Spring Base		1	1	1	1	1	
9	4B5×10	Screw for 305122		2	2	2	2	2	
10	E07003	Fastener Spring(ST8)		2	3	2	2	3	
11	9/64S40004	Screw for E07003		4	6	4	4	6	
12	305021	Cutter Cover		-	1	-	-	1	
13	E07001	Hinge(2FZ-11)		-	1	-	-	1	
14	9/64S40004	Screw for E07001		-	2	-	-	2	
15	11/64S40005	Screw for E07001		-	2	-	-	2	
16	305141	Gasket	丸面パッキン	1	1	1	1	1	
17	035191	Side Cover	丸面	1	1	1	1	1	
18	035201	Side Cover Retainer	丸面止め板	1	1	1	1	1	
19	10S4×12K	Screw for 035201,035191,305141	ネジ	6	6	6	6	6	
20	305012	Body Head Cover	本体カバー	1	1	1	1	1	
21	4B5×20	Screw for 305012	ネジ	6	6	6	6	6	
22	305081	Top Cover A	上蓋 A	1	1	1	1	1	
23	305091	Gasket	オイルシート	2	2	2	2	2	
24	10S4×12K	Screw for 305081,305082,305091	ネジ	12	12	12	12	12	
25	305082	Top Cover B	上蓋 B	1	1	1	1	1	
26	SC63278	Screw	ネジ	1	1	1	1	1	
27	305052	Gasket	オイルシート	1	1	1	1	1	
28	305042	Face Plate, upper	上面板	1	1	1	1	1	
29	3S5×12	Screw for 305042,304052	ネジ	9	9	9	9	9	
30	11G1/8NPT	Plug	プラグ	1	1	1	1	1	
31	305111	Needle Bar Cover	針棒カバー	1	1	1	1	1	
32	3S5×10	Screw for 305111	ネジ	3	3	3	3	3	
33	065401	Rubber Bushing	キャップ	1	1	1	1	1	
34	305151	Face Plate, lower	下面板	-	1	1	-	1	
35	3S4×8	Screw for 305151	ネジ	2	2	2	2	2	
36	305072	Gasket	オイルシート	1	1	1	1	1	
37	305062	Inside Cover	裏面板	1	1	1	1	1	
38	3S5×15	Screw for 305062,305072	ネジ	15	15	15	15	15	
39	305152	Face Plate, lower	下面板	1	-	-	1	-	
40	305271	Side Cover	サイドカバー	1	-	1	1	-	
41	11/64S40005	Screw	ネジ	3	-	3	3	-	
42	305281	Cloth Plate	ベースカバー	1	-	-	1	-	
43	305261	Looper Thread Cover	下糸カバー	1	1	1	1	1	
44	11/64S40005	Screw for 305261	ネジ	1	1	1	1	1	
45	255351	Rubber Bushing	キャップ	3	-	3	3	-	
46	305211	Cloth Plate	ベースカバー	-	-	1	-	-	
47	305201	Cloth Plate Base	ベースカバー土台	-	-	1	-	-	
48	3/16S28018	Screw for 305201	ネジ	-	-	2	-	-	
49	305241	Looper Thread Take-Up Cover B	下糸天秤カバーB	(1)	(1)	(1)	-	-	
50	305171	Post	支柱	(1)	(1)	(1)	(1)	(1)	
51	305162	Looper Thread Take-Up Cover A	下糸天秤カバーA	(1)	(1)	(1)	(1)	(1)	
52	15/64S28017	Screw for 305162	ネジ	(1)	(1)	(1)	(1)	(1)	
53	5/16W05201	Washer for 305162	ワッシャー	(1)	(1)	(1)	(1)	(1)	
54	3/16S32004	Screw for 305162	ネジ	(1)	(1)	(1)	(1)	(1)	
55	305242	Looper Thread Take-Up Cover B	下糸天秤カバーB	-	-	-	(1)	(1)	For Export 海外仕様

02-1. THREAD TENSION & OILING PARTS
糸調子、給油関係

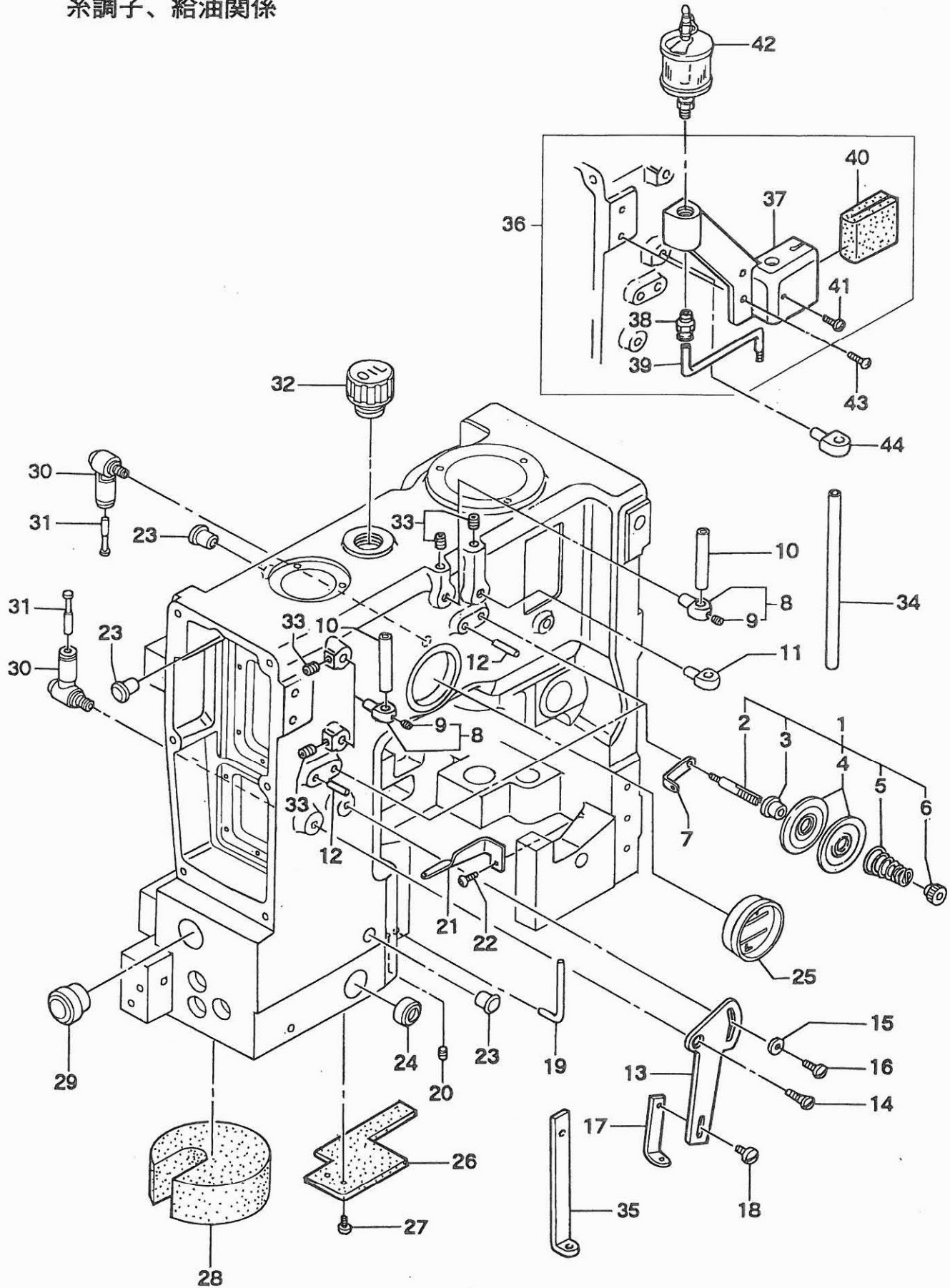

02-1. THREAD TENSION & OILING PARTS
糸調子、給油関係

図番 Ref. No.	部品番号 Part No.	部 品 名 称 Description		個数 Qty					摘 要 Remarks
				A	C	P	AW	CW	
1	065151E	Thread Tension Ass'y	糸調子組	2	2	2	-	-	(2-6)
2	065151	Tension Post	糸調子芯棒	2	2	2	-	-	
3	HA1348	Tension Post Ferrule	糸調子スリーブ	2	2	2	-	-	
4	80676A	Tension Disc	糸調子皿	4	4	4	-	-	
5	065181	Tension Spring	糸調子スプリング	2	2	2	-	-	
6	065171	Tension Nut	糸調子ナット	2	2	2	-	-	
7	245071	Thread Guide	糸ガイド	2	2	2	-	-	
8	075081	Frame Thread Eyelet Support	糸ガイド	3	3	3	-	-	(9)
9	11/64S40501	Screw for 075091	ネジ	3	3	3	-	-	
10	075091	Frame Thread Eyelet	糸ガイドパイプ	3	3	1	-	-	
11	065211	Frame Thread Eyelet	糸ガイド	1	1	1	-	-	
12	80667	Tension Disc Stop Pin	糸調子皿止メ	2	2	2	-	-	
13	035031	Needle Thread Controller A	上糸調節A	1	1	1	-	-	
14	11/64S40014	Screw for 035031	ネジ	1	1	1	-	-	
15	11/64W15103	Washer for 035031	ワッシャー	1	1	1	-	-	
16	11/64S40009	Screw for 035031	ネジ	1	1	1	-	-	
17	035042	Needle Thread Controller B	上糸調節B	1	1	1	-	-	
18	9/64S40011	Screw for 035042	ネジ	1	1	1	-	-	
19	305131	Needle Thread Guide	上糸掛ケ	1	1	1	-	-	
20	1S5×5	Screw for 305131	ネジ	1	1	1	-	-	
21	255262	Looper Thread Guide	下糸ガイド	1	1	1	-	-	
22	3S4×10	Screw for 255262	ネジ	1	1	1	-	-	
23	065401	Rubber Bushing	キャップ	3	3	3	3	3	
24	D05003	Oil Gauge (OLG 207R)	オイルゲージ	1	1	1	1	1	
25	D05007	Oil Gauge (KDM-40)	オイルゲージ	1	1	1	1	1	
26	305231	Felt	給油綿	1	1	1	1	1	
27	3S4×6	Screw for 305231	ネジ	2	2	2	2	2	
28	035821	Fence	フェンス	1	1	1	1	1	
29	D09002	Rubber Bushing (EZ3020AO)	給油口蓋	1	1	1	1	1	
30	D07055	Tube Fitting,elbow (POL8-02)	ユニバーサルエルボ	2	2	2	2	2	
31	D07056	Tube Fitting,plug (PP8)	プラグ	2	2	2	2	2	
32	D09005	Plug (BM-3/4)	給油口蓋	1	1	1	1	1	
33	1S5×6	Screw	ネジ	4	4	4	-	-	
34	305291	Frame Thread Eyelet	糸ガイドパイプ	-	-	2	-	-	Single Thread (単環用)
35	305251	Needle Thread Controller	上糸調節	(1)	(1)	(1)	-	-	
36	255392A	Needle Thread Oiler Ass'y	上糸給油器組	(1)	(1)	(1)	-	-	(37-41)
37	255392	Needle Thread Oiler Base	上糸給油器土台	(1)	(1)	(1)	-	-	
38	D07057	Tube Fitting,straight (PC4-01M)	ワンタッチ継手	(1)	(1)	(1)	-	-	Special Order 特注
39	8FU2-4×130	Oil Tube	給油パイプ	(1)	(1)	(1)	-	-	
40	105521	Felt	給油綿	(1)	(1)	(1)	-	-	
41	9/64S40005	Screw	ネジ	(1)	(1)	(1)	-	-	
42	D03002	Oiler (38-1/4PF)	オイルー	(1)	(1)	(1)	-	-	
43	3S5×15	Screw for 255392	ネジ	(2)	(2)	(2)	-	-	
44	065211	Frame Thread Eyelet	糸ガイド	(1)	(1)	(1)	-	-	

02-2. THREAD TENSION & NEEDLE THREAD OILER (DS-9AW, DS-9CW)

糸調子、上糸給油器関係

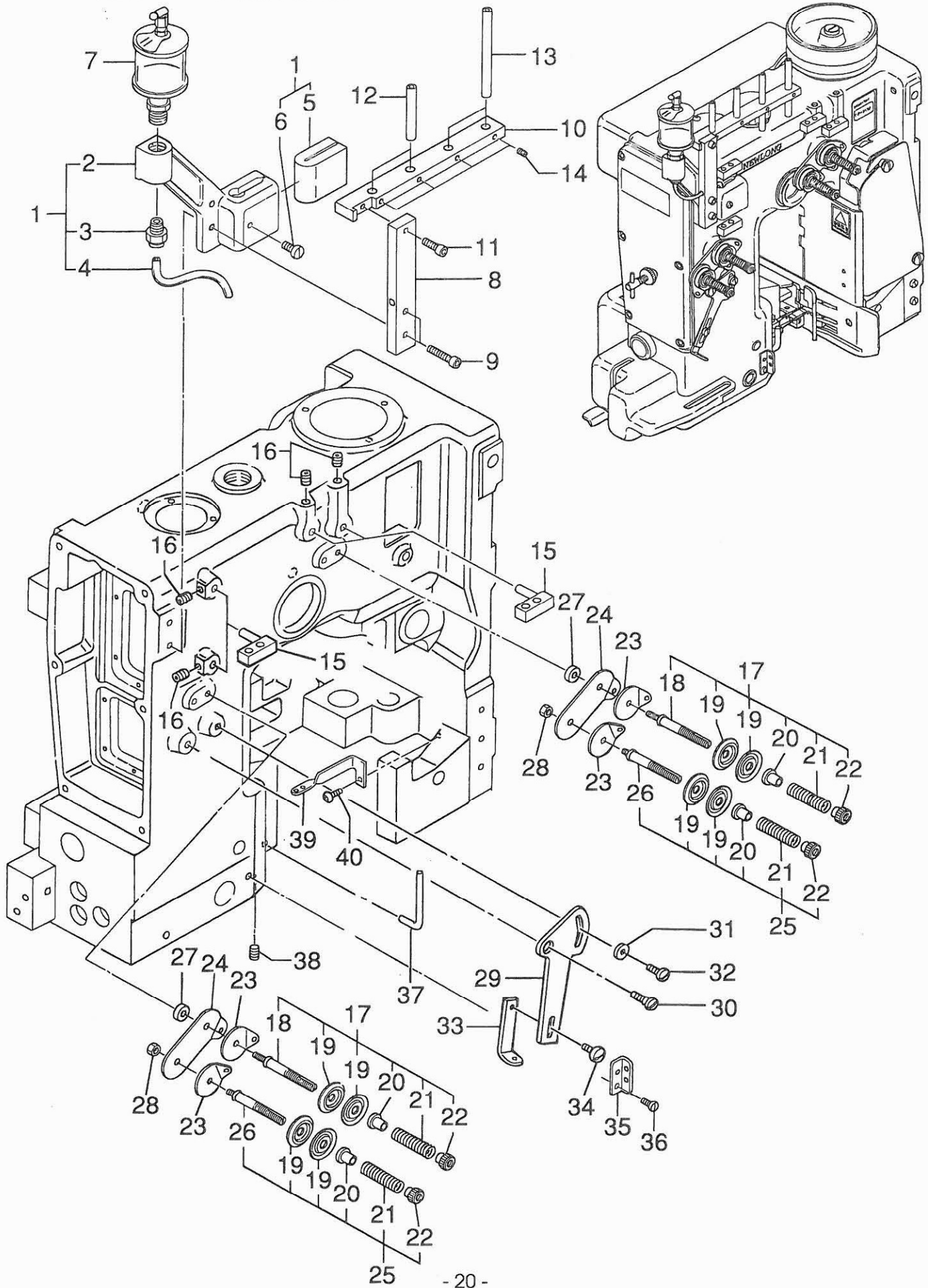

02-2. THREAD TENSION & NEEDLE THREAD OILER (DS-9AW,DS-9CW)
糸調子、上糸給油器関係

図番 Ref. No.	部品番号 Part No.	部品名称 Description		個数 Q'ty		摘要 Remarks
				9AW	9CW	
1	305401A	Needle Thread Oiler Ass'y	上糸給油器 組	1	1	(2-6)
2	305401	Needle Thread Oiler	上糸給油器	1	1	
3	D07057	Tube Fitting, straight(PC4-01M)	ワンタッチ継手	1	1	
4	8FU2-4×130	Oile Tube	給油パイプ	1	1	
5	105521	Felt	給油綿	1	1	
6	9/64S40005	Screw	ネジ	1	1	
7	D03002	Oile(38-1/4PF)	オイラー	1	1	
8	305371	Thread Guide Holder Base	糸ガイドホルダーベース	1	1	
9	4B5×25	Screw	ネジ	2	2	
10	305361	Thread Guide Holder	糸ガイドホルダー	1	1	
11	4B5×15	Screw	ネジ	1	1	
12	075091	Frame Thread Eyelet	糸ガイドパイプ	2	2	
13	305441	Frame Thread Eyelet	糸ガイドパイプ	2	2	
14	1S5×5	Screw for 075091,305441	ネジ	4	4	
15	105561	Thread Eyelet	糸ガイド	4	4	
16	1S5×5	Screw for 105561	ネジ	4	4	
17	035021A	Thread Tension Ass'y	糸調子組	2	2	(18-22)
18	035021	Tension Post	糸調子芯棒	2	2	
19	065261	Tension Disc	糸調子皿	8	8	
20	035071	Tension Post Ferrule	糸調子スリーブ	4	4	
21	035061	Tension Spring	糸調子スプリング	4	4	
22	065171	Tension Nut	糸調子ナット	4	4	
23	015011	Tension Thread Guide	糸ガイド座金	4	4	
24	035011	Tension Thread Guide	糸ガイド座金	2	2	
25	035022A	Thread Tension Ass'y	糸調子組	2	2	(19-22,26)
26	035022	Tension Post	糸調子芯棒	2	2	
27	305431	Collar	カラー	2	2	
28	11/64N40104	Nut	ナット	2	2	
29	035031	Needle Thread Controller A	上糸調節A	1	1	
30	11/64S40014	Screw for 035031	ネジ	1	1	
31	11/64W15103	Washer for 035031	ワッシャー	1	1	
32	11/64S40009	Screw for 035031	ネジ	1	1	
33	035043	Needle Thread Controller B	上糸調節B	1	1	
34	9/64S40011	Screw for 035043	ネジ	1	1	
35	305381	Needle Thread Guide	上糸ガイド	1	1	
36	11/64S40005	Screw for 305381	ネジ	1	1	
37	305131	Needle Thread Guide	上糸ガイド	1	1	
38	1S5×5	Screw for 305131	ネジ	1	1	
39	305391	Looper Thread Guide	糸ガイド	1	1	
40	3S4×10	Screw for 305391	ネジ	1	1	